



RUBBER EXPANSION JOINTS

SPOOL-TYPE STANDARD ARCH 150, 200, 200XL



- **The heavy duty proven "industry work horse"**
- Time tested performer
- Fabric and steel reinforced
- Constructed for maximum strength and reliability.
- Available in multi-arch, taper, offset and special constrictions

SUPER-FLEX WIDE ARCH DESIGN 1000, 1100, 1200



- **Twice the movement capabilities than standard arch**
- Lower spring rates required for movement
- Fabric and steel reinforced
- Suitable for pressures up to 200 PSI and vacuum service
- Available in multi-arch, offset and special constructions

LIGHTWEIGHT APPLICATION DESIGN - STYLE 189



- Lightweight construction
- Low spring rate forces
- Can be built to handle temperatures up to 350°F
- **Less force to move; allows maximum movements**
- Available in multi-arch, taper, offset and for high temperature applications

SPHERICAL DESIGN - STYLE 800, 802, 803

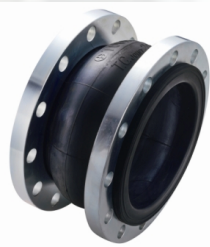

- Minimizes water hammer and hydraulic shock
- Less force to move; allows maximum movements
- **"All-in-one" design eliminates the need for retaining rings**
- Available in Twin Sphere design for greater movement capabilities
- Floating flange design provides easy installation

FLUE DUCT AND NAVY FAN CONNECTORS - STYLE 600



- Designed to absorb thermal movements and sound vibrations
- Liners and insulation can allow temperatures to 500°F
- **Suitable for Flue Duct Applications**
- Available in multiple arch, taper, offset and special constructions
- Custom Drilled or un-drilled

For more information on Rubber Expansion Joints, please refer to our **PRODUCTS** section - **EXPANSION JOINTS**

Rubber Types

SDSI uses varying rubber types. Selecting the right polymer base is important to each project. Our experienced staff works with you to determine what type of rubber works best for your application.

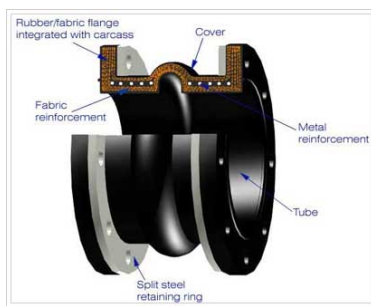

Neoprene (Chloroprene)

Good general purpose rubber with properties close to natural rubber, but is synthetically produced. Better resistance to oils and solvents compared to natural rubber but similar low compression set. Can be compounded for flame resistance. Good weathering resistance. Poorer low temperature performance compared to natural rubber. Not good in applications with concentrated acids or alkalis. Maximum continuous operating temperature is about 275°F.

Nitrile (Buna)

Much better oil and solvent resistance compared to either natural rubber or Neoprene. Recommended for most oil field applications. Can be formulated for use at low temperatures. Good compression set and abrasion resistance, but poor weathering resistance. Can be used with concentrated acids and alkalis but there are better alternatives. Maximum continuous operating temperature is about 275°F.

HNBR (Hydrogenated Nitrile)

Similar to Nitrile but with improvements in heat and ozone resistance. Can be formulated for low temperature applications. Excellent for oil field service. Usually not recommended in applications with concentrated acids or alkalis. Very high cost. Maximum continuous operating temperature is about 350°F.

EPDM

Exceptional resistance to weathering and ozone. Excellent resistance to water, most gases, steam, and heat aging. Good for exposure to concentrated acids and alkalis, but not recommended for exposure to oils and solvents. Maximum continuous operating temperature is about 350°F.

FKM (Viton®)

High cost, but high performance material Outstanding resistance to most chemicals, oils and solvents Good oxidation and ozone resistance Maximum continuous operating temperature is about 650°F "Viton" is a trademark of DuPont and signifies material produced by DuPont

Styrene Butadiene (SBR)

Originally developed as a low cost substitute for natural rubber Good water resistance and abrasion resistance Poor weathering resistance, but can overcome with specific raw materials Not recommended for contact with oils and solvents Not used with concentrated acids or alkalis Maximum continuous operating temperature is about 225°F

Natural Rubber

The raw material to make natural rubber actually does come from trees Produces compounds with high tensile strength, tear strength, tear and abrasion resistance Can be used at lower temperatures, low compression set, and high resilience Not recommended for severe applications with oil and solvent exposure; subject to aging by sun, ozone, and heat Also not good for applications in contact with concentrated acids or alkalis Maximum continuous operating temperature is about 225°F

Butyl

Very good resistance to most gases including air highly resistant to ozone and weathering Abrasion resistance close to natural rubber and good for concentrated acids and alkalis Not recommended for petroleum product exposure Maximum continuous operating temperature is about 300°F

AFLAS

Similar to FKM, but with improved steam aging resistance Lower overall temperature resistance Very costly and seldom used except in very specific oil field applications Maximum continuous operating temperature is about 450°F



SAN DIEGO SEAL, INC.

7635 RONSON ROAD • SAN DIEGO, CA 92111
TEL: 858-278-3270 • FAX: 858-278-2950
E-MAIL: sales@sandiegoseal.com
VISIT US AT: www.sandiegoseal.com

EXPANSION JOINT DIMENSION CHART - 150 LB. COMMERCIAL DRILL

Nominal Pipe Size	*FACE to FACE	FLANGE O.D.	Bolt Circle	Number of Bolt Holes	Diameter of Bolt Holes
1/2"	6	3 1/2"	2 3/8"	4	5/8"
3/4"	6	3 7/8"	2 3/4"	4	5/8"
1"	6	4 1/4"	3 1/8"	4	5/8"
1 1/4"	6	4 5/8"	3 1/2"	4	5/8"
1 1/2"	6	5"	3 7/8"	4	5/8"
2"	6-8-10-12	6"	4 3/4"	4	3/4"
2 1/2"	6-8-10-12	7"	5 1/2"	4	3/4"
3"	6-8-10-12	7 1/2"	6"	4	3/4"
3 1/2"	6-8-10-12	8 1/2"	7"	8	3/4"
4"	6-8-10-12	9"	7 1/2"	8	3/4"
5"	6-8-10-12	10"	8 1/2"	8	7/8"
6"	6-8-10-12	11"	9 1/2"	8	7/8"
8"	6-8-10-12	13 1/2"	11 3/4"	8	7/8"
10"	6-8-10-12	16"	14 1/4"	12	1"
12"	6-8-10-12	19"	17"	12	1"
14"	8-10-12	21"	18 3/4"	12	1 1/8"
16"	8-10-12	23 1/2"	21 1/4"	16	1 1/8"
18"	8-10-12	25"	22 3/4"	16	1 1/4"
20"	8-10-12	27 1/2"	25"	20	1 1/4"
22"	10-12	29 1/2"	27 1/4"	20	1 3/8"
24"	10-12	32"	29"	20	1 3/8"
26"	10-12	34 1/4"	31 3/4"	24	1 3/8"
28"	10-12	36 1/2"	34"	28	1 3/8"
30"	10-12	38 3/4"	36"	28	1 3/8"
32"	10-12	41 3/4"	38 1/2"	28	1 5/8"
34"	10-12	43 3/4"	40 1/2"	32	1 5/8"
36"	10-12	46"	42 3/4"	32	1 5/8"
38"	10-12	48 3/4"	45 1/4"	32	1 5/8"
40"	10-12	50 3/4"	47 1/4"	36	1 5/8"
42"	10-12	53"	49 1/4"	36	1 5/8"
44"	10-12	55 1/4"	51 3/4"	40	1 5/8"
46"	10-12	57 1/4"	53 3/4"	40	1 5/8"
48"	10-12	59 1/2"	56"	44	1 5/8"

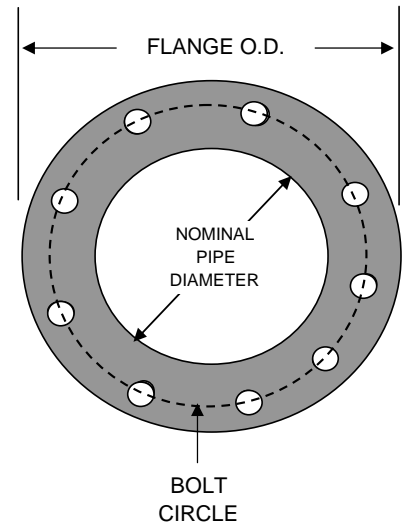
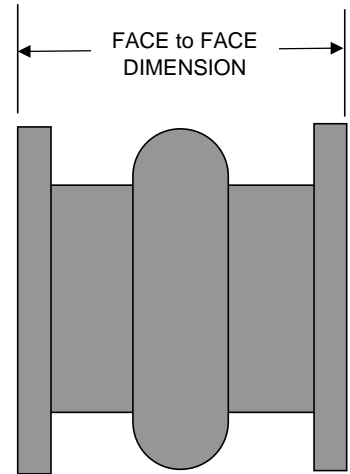

*STANDARD FACE TO FACE DIMENSIONS
 IF SIZE OTHER THAN ON CHART PLEASE CONTACT SALES

EXPANSION JOINT DIMENSION CHART - 300 LB. COMMERCIAL DRILL

Nominal Pipe Size	*FACE to FACE	FLANGE O.D.	Bolt Circle	Number of Bolt Holes	Diameter of Bolt Holes
1"	6	4 7/8"	3 1/2"	4	3/4"
1 1/4"	6	5 1/4"	3 7/8"	4	3/4"
1 1/2"	6	6 1/8"	4 1/2"	4	7/8"
2"	6	6 1/2"	5"	8	3/4"
2 1/2"	6	7 1/2"	5 7/8"	8	7/8"
3"	6-8-10-12	8 1/4"	6 5/8"	8	7/8"
3 1/2"	6-8-10-12	9"	7 1/4"	8	7/8"
4"	6-8-10-12	10"	7 7/8"	8	7/8"
5"	6-8-10-12	11"	9 1/4"	8	7/8"
6"	6-8-10-12	12 1/2"	10 5/8"	12	7/8"
8"	6-8-10-12	15"	13"	12	1"
10"	6-8-10-12	17 1/2"	15 1/4"	16	1 1/8"
12"	6-8-10-12	20 1/2"	17 3/4"	16	1 1/4"
14"	8-10-12	23"	20 1/4"	20	1 1/4"
16"	8-10-12	25 1/2"	22 1/2"	20	1 3/8"
18"	8-10-12	28"	24 3/4"	24	1 3/8"
20"	8-10-12	30 1/2"	27"	24	1 3/8"
22"	10-12	33"	29 1/4"	24	1 5/8"
24"	10-12	36"	32"	24	1 5/8"
26"	10-12	38 1/4"	34 1/2"	28	1 7/8"
28"	10-12	40 3/4"	37"	28	1 7/8"
30"	10-12	43"	39 1/4"	28	1 7/8"
32"	10-12	45 1/4"	41 1/2"	28	1 7/8"
34"	10-12	47 1/2"	43 1/2"	28	1 7/8"
36"	10-12	50"	46"	32	2 1/8"
38"	10-12	52 1/4"	48"	32	2 1/8"
40"	10-12	54 1/2"	50 1/4"	36	2 1/8"
42"	10-12	57"	52 3/4"	36	2 1/8"
44"	10-12	59 1/4"	55"	36	2 1/8"
46"	10-12	61 1/2"	57 1/4"	40	2 1/8"
48"	10-12	65"	60 3/4"	40	2 1/8"

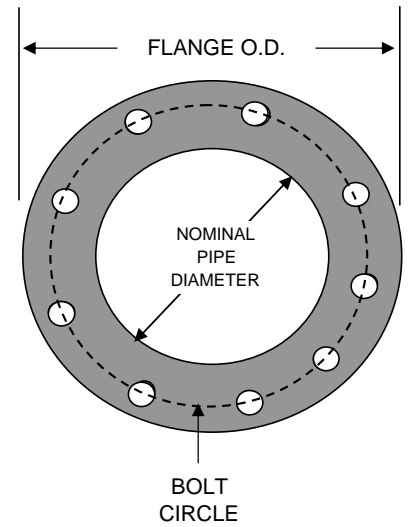
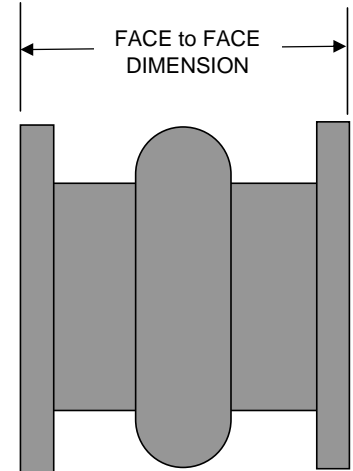

*STANDARD FACE TO FACE DIMENSIONS
 IF SIZE OTHER THAN ON CHART PLEASE CONTACT SALES

7635 RONSON ROAD • SAN DIEGO, CA 92111 • TEL: 858-278-3270 • FAX: 858-278-2950
E-MAIL: sales@sandiegoseal.com • VISIT US AT: www.sandiegoseal.com

EXPANSION JOINT DIMENSION CHART - NAVY DRILL

Nominal Pipe Size	*FACE to FACE	FLANGE O.D.	BOLT CIRCLE	Number of Bolt Holes	Diameter of Bolt Holes
1/2"	6	3 9/16"	2 7/16"	3	9/16"
3/4"	6	3 13/16"	2 11/16"	4	9/16"
1"	6	4 1/4"	3 1/8"	4	9/16"
1 1/4"	6	4 1/2"	3 3/8"	4	9/16"
1 1/2"	6	5 1/16"	3 15/16"	6	9/16"
2"	6-8-10-12	5 9/16"	4 7/16"	6	9/16"
2 1/2"	6-8-10-12	6 1/8"	5"	6	9/16"
3"	6-8-10-12	6 5/8"	5 1/2"	8	9/16"
3 1/2"	6-8-10-12	7 3/16"	6 1/16"	8	9/16"
4"	6-8-10-12	7 11/16"	6 9/16"	8	9/16"
5"	6-8-10-12	9 1/16"	7 13/16"	10	11/16"
6"	6-8-10-12	10 1/8"	8 7/8"	12	11/16"
8"	6-8-10-12	12 3/8"	11 1/16"	14	11/16"
10"	6-8-10-12	15"	13 7/16"	15	13/16"
12"	6-8-10-12	17 5/8"	16 1/16"	18	13/16"
14"	8-10-12	19 1/8"	17 3/8"	19	15/16"
16"	8-10-12	21 3/16"	19 7/8"	20	15/16"
18"	8-10-12	23 1/4"	21 1/2"	22	15/16"
20"	8-10-12	25 13/16"	23 13/16"	24	1 1/16"
22"	10-12	27 7/8"	25 7/8"	26	1 1/16"
24"	10-12	30"	28"	28	1 1/16"
26"	10-12	32 9/16"	30 5/16"	30	1 3/16"
28"	10-12	34 11/16"	32 7/16"	32	1 3/16"
30"	10-12	36 13/16"	34 9/16"	35	1 3/16"
32"	10-12	39"	36 3/4"	36	1 3/16"
34"	10-12	41"	38 3/4"	36	1 3/16"
36"	10-12	43 7/8"	41 3/8"	36	1 5/16"
38"	10-12	46 1/8"	43 3/8"	36	1 5/16"
40"	10-12	48 1/8"	45 3/8"	36	1 5/16"
42"	10-12	50 1/4"	47 3/4"	38	1 5/16"
46"	10-12	54 1/2"	52"	40	1 5/16"

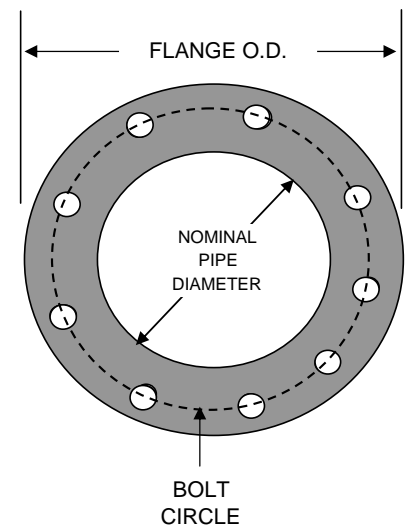
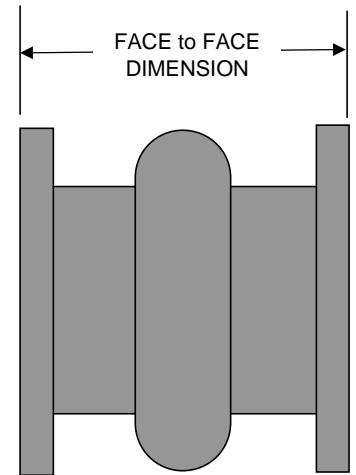

*STANDARD FACE TO FACE DIMENSIONS
IF SIZE OTHER THAN ON CHART PLEASE CONTACT SALES